

STATE OF NORTH CAROLINA
DIVISION OF HIGHWAYS

TRANSPORTATION MANAGEMENT PLAN

CATAWBA COUNTY

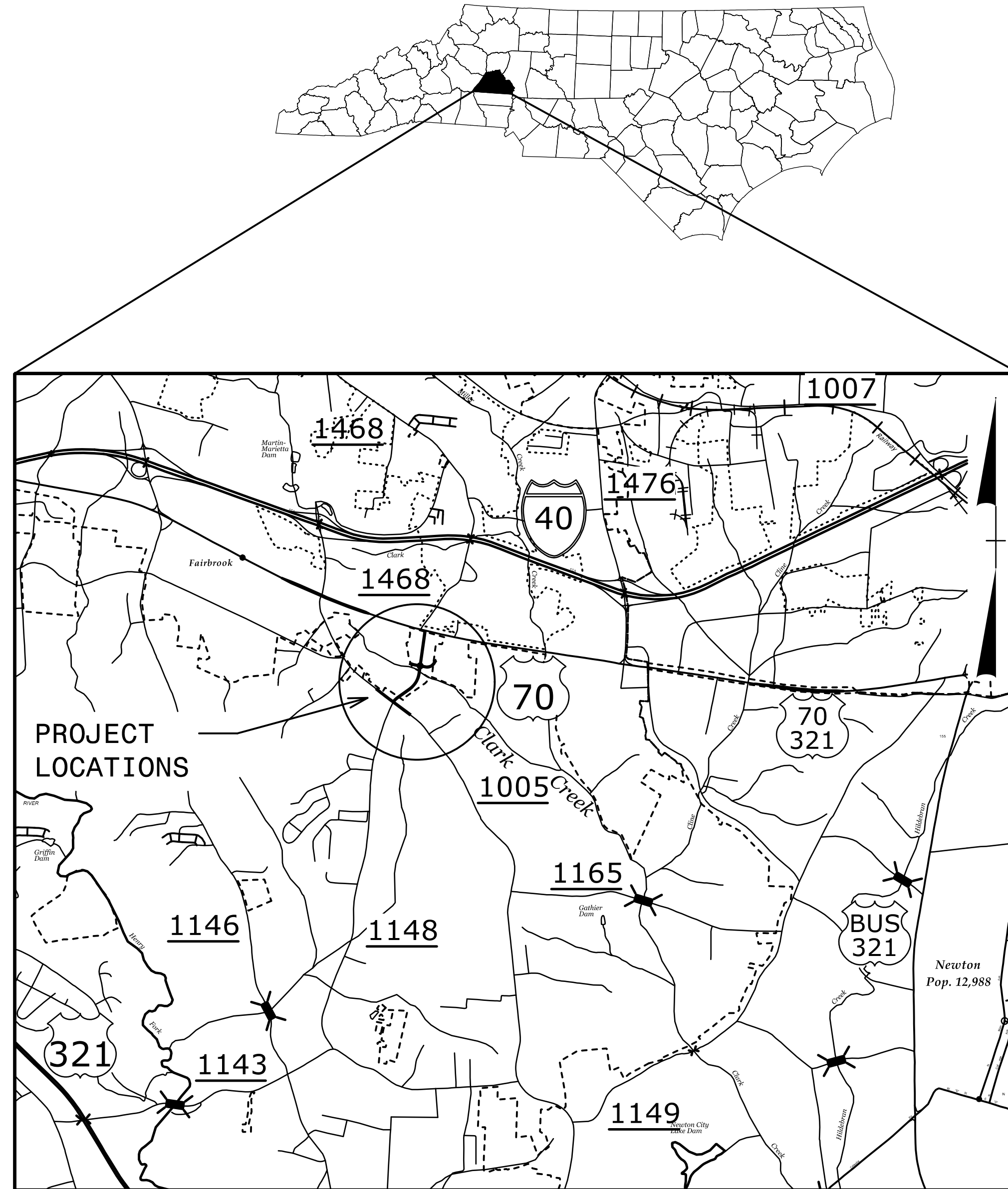

INDEX OF SHEETS

SHEET NO.	TITLE
TMP-1	TITLE SHEET, VICINITY MAP AND INDEX OF SHEETS
TMP-1A	LIST OF APPLICABLE ROADWAY STANDARD DRAWINGS, AND LEGEND
TMP-1B	TRANSPORTATION OPERATIONS PLAN: (MANAGEMENT STRATEGIES, GENERAL NOTES AND LOCAL NOTES)
TMP-2	PHASING
TMP-3	PHASE I OVERVIEW
TMP-4	PHASE II OVERVIEW
TMP 5 THRU 8	PHASE II DETAILS

SHEET NO.
TMP-1

TIP PROJECT: U-5510

DOCUMENT NOT CONSIDERED FINAL
UNLESS ALL SIGNATURES COMPLETED

APPROVED: _____
DATE: _____

SEAL

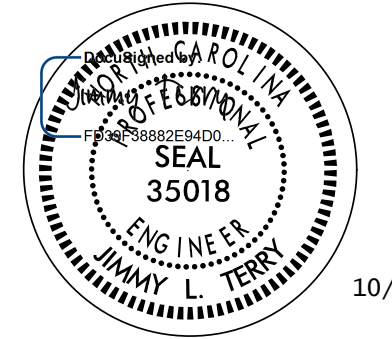

10/3/2017

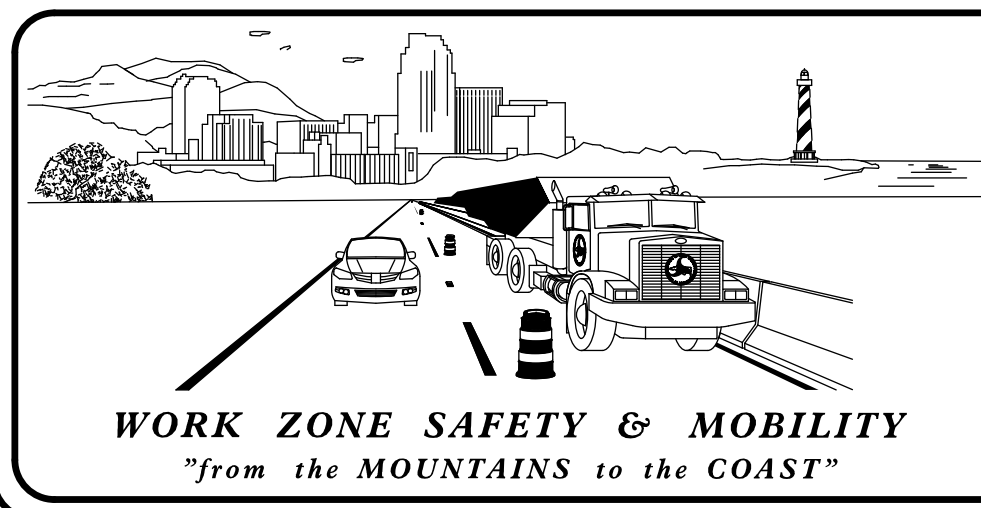

PLAN PREPARED FOR N.C.D.O.T. BY:

TGS ENGINEERS
TGS ENGINEERS
804-C N. LAFAYETTE ST
SHELBY, NC 28150
PH (704) 476-0003
CORP. LICENSE NO.: C-0275

JIMMY L. TERRY, PE PROJECT ENGINEER
SANDRA G. MELVIN DESIGN TECHNICIAN



9/29/2017 10:55:00 AM User: jsmelvin

ROADWAY STANDARD DRAWINGS

THE FOLLOWING ROADWAY STANDARDS AS SHOWN IN "ROADWAY STANDARD DRAWINGS" - PROJECT SERVICES UNIT - N.C. DEPARTMENT OF TRANSPORTATION - RALEIGH, N.C., DATED JANUARY 2012 ARE APPLICABLE TO THIS PROJECT AND BY REFERENCE HEREBY ARE CONSIDERED A PART OF THESE PLANS:

STD. NO.	TITLE
1101.01	WORK ZONE ADVANCE WARNING SIGNS
1101.02	TEMPORARY LANE CLOSURES
1101.03	TEMPORARY ROAD CLOSURES
1101.04	TEMPORARY SHOULDER CLOSURES
1101.05	WORK ZONE VEHICLE ACCESSES
1101.11	TRAFFIC CONTROL DESIGN TABLES
1110.01	STATIONARY WORK ZONE SIGNS
1110.02	PORTABLE WORK ZONE SIGNS
1115.01	FLASHING ARROW BOARDS
1130.01	DRUM
1135.01	CONES
1145.01	BARRICADES
1150.01	FLAGGING DEVICES
1180.01	SKINNY-DRUM
1205.01	PAVEMENT MARKINGS - LINE TYPES AND OFFSETS
1205.02	PAVEMENT MARKINGS - TWO-LANE AND MULTI-LANE ROADWAYS
1205.04	PAVEMENT MARKINGS - INTERSECTIONS
1205.05	PAVEMENT MARKINGS - TURN LANES
1205.07	PAVEMENT MARKINGS - PEDESTRIAN CROSSWALKS
1205.09	PAVEMENT MARKINGS - PAINTED ISLANDS
1250.01	RAISED PAVEMENT MARKERS - INSTALLATION SPACING
1251.01	RAISED PAVEMENT MARKERS - PERMANENT AND TEMPORARY

LEGEND

GENERAL

- DIRECTION OF TRAFFIC FLOW
- DIRECTION OF PEDESTRIAN TRAFFIC FLOW
- EXIST. PVMT.
- NORTH ARROW
- PROPOSED PVMT.
- TEMP. SHORING (LOCATION PURPOSES ONLY)

- WORK AREA
- REMOVAL
- USER DEFINED (IF NEEDED)
- USER DEFINED (IF NEEDED)

SIGNALS

- EXISTING
- PROPOSED
- TEMPORARY

PAVEMENT MARKINGS

- EXISTING LINES
- TEMPORARY LINES

TRAFFIC CONTROL DEVICES

- BARRICADE (TYPE III)
- CONE
- DRUM SKINNY DRUM TUBULAR MARKER
- TEMPORARY CRASH CUSHION
- FLASHING ARROW BOARD
- FLAGGER
- LAW ENFORCEMENT
- TRUCK MOUNTED ATTENUATOR (TMA)
- CHANGEABLE MESSAGE SIGN

TEMPORARY SIGNING

- PORTABLE SIGN
- STATIONARY SIGN
- STATIONARY OR PORTABLE SIGN

PAVEMENT MARKERS

- CRYSTAL/CRYSTAL
- CRYSTAL/RED
- YELLOW/YELLOW

PAVEMENT MARKING SYMBOLS

- PAVEMENT MARKING SYMBOLS

9/28/2017
 \\TC\U-5510\TrafficControl\TCP\U-5510_TC_TMP_01A(Rdw_Std).dgn
 User:rsmevin

DOCUMENT NOT CONSIDERED FINAL
UNLESS ALL SIGNATURES COMPLETED

APPROVED: _____ DATE: _____

SEAL

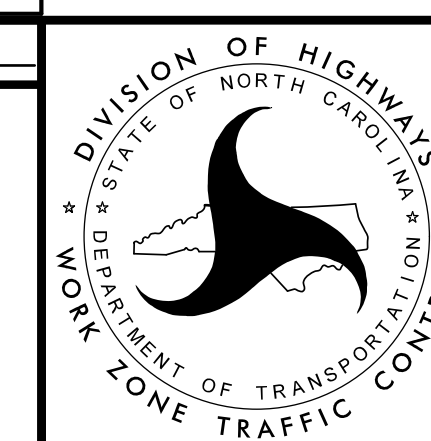

ROADWAY STANDARD
DRAWINGS & LEGEND

GENERAL NOTES

CHANGES MAY BE REQUIRED WHEN PHYSICAL DIMENSIONS IN THE DETAIL DRAWINGS, STANDARD DETAILS, AND ROADWAY DETAILS ARE NOT ATTAINABLE TO MEET FIELD CONDITIONS OR RESULT IN DUPLICATE OR UNDESIRE OVERLAPPING OF DEVICES. MODIFICATION MAY INCLUDE: MOVING, SUPPLEMENTING, COVERING, OR REMOVAL OF DEVICES AS DIRECTED BY THE ENGINEER.

THE FOLLOWING GENERAL NOTES APPLY AT ALL TIMES FOR THE DURATION OF THE CONSTRUCTION PROJECT EXCEPT WHEN OTHERWISE NOTED IN THE PLAN OR DIRECTED BY THE ENGINEER.

TIME RESTRICTIONS

A) DO NOT CLOSE OR NARROW TRAVEL LANES AS FOLLOWS:

ROAD NAME	DAY AND TIME RESTRICTIONS
US 70 STARTOWN RD (-Y1-)	MON THRU FRI 6:00 AM TO 9:00 AM MON THRU FRI 4:00 PM TO 7:00 PM

B) DO NOT CLOSE OR NARROW TRAVEL LANES DURING HOLIDAYS AND SPECIAL EVENTS AS FOLLOWS:

ROAD NAME
US 70 STARTOWN RD

HOLIDAY

- FOR ANY UNEXPECTED OCCURRENCE THAT CREATES UNUSUALLY HIGH TRAFFIC VOLUMES, AS DIRECTED BY THE ENGINEER.
- FOR NEW YEAR'S, BETWEEN THE HOURS OF 4:00 P.M. DECEMBER 31st TO 9:00 A.M. JANUARY 2ND. IF NEW YEAR'S DAY IS ON A FRIDAY, SATURDAY, SUNDAY, OR MONDAY THEN UNTIL 9:00 A.M. THE FOLLOWING TUESDAY.
- FOR EASTER, BETWEEN THE HOURS OF 4:00 P.M. THURSDAY AND 9:00 A.M. MONDAY.
- FOR MEMORIAL DAY, BETWEEN THE HOURS OF 4:00 P.M. FRIDAY TO 9:00 A.M. TUESDAY.
- FOR INDEPENDENCE DAY, BETWEEN THE HOURS OF 4:00 P.M. THE DAY BEFORE INDEPENDENCE DAY AND 9:00 A.M. THE DAY AFTER INDEPENDENCE DAY.

IF INDEPENDENCE DAY IS ON A FRIDAY, SATURDAY, SUNDAY OR MONDAY THEN BETWEEN THE HOURS OF 4:00 P.M. THE THURSDAY BEFORE INDEPENDENCE DAY AND 9:00 A.M. THE TUESDAY AFTER INDEPENDENCE DAY.
- FOR LABOR DAY, BETWEEN THE HOURS OF 4:00 P.M. FRIDAY AND 9:00 A.M. TUESDAY.
- FOR THANKSGIVING DAY, BETWEEN THE HOURS OF 4:00 P.M. TUESDAY TO 9:00 A.M. MONDAY.
- FOR CHRISTMAS, BETWEEN THE HOURS OF 4:00 P.M. THE FRIDAY BEFORE THE WEEK OF CHRISTMAS DAY AND 9:00 A.M. THE FOLLOWING TUESDAY AFTER THE WEEK OF CHRISTMAS.

LANE AND SHOULDER CLOSURE REQUIREMENTS

- C) REMOVE LANE CLOSURE DEVICES FROM THE LANE WHEN WORK IS NOT BEING PERFORMED BEHIND THE LANE CLOSURE OR WHEN A LANE CLOSURE IS NO LONGER NEEDED OR AS DIRECTED BY THE ENGINEER.
- D) WHEN PERSONNEL AND/OR EQUIPMENT ARE WORKING WITHIN 15 FT OF AN OPEN TRAVEL LANE, CLOSE THE NEAREST OPEN SHOULDER USING ROADWAY STANDARD DRAWING NO. 1101.04 UNLESS THE WORK AREA IS PROTECTED BY BARRIER OR GUARDRAIL OR A LANE CLOSURE IS INSTALLED.
- E) WHEN PERSONNEL AND/OR EQUIPMENT ARE WORKING ON THE SHOULDER ADJACENT TO AN UNDIVIDED FACILITY AND WITHIN 5 FT OF AN OPEN TRAVEL LANE, CLOSE THE NEAREST OPEN TRAVEL LANE USING ROADWAY STANDARD DRAWING NO. 1101.02 UNLESS THE WORK AREA IS PROTECTED BY BARRIER OR GUARDRAIL.
- F) WHEN PERSONNEL AND/OR EQUIPMENT ARE WORKING WITHIN A LANE OF TRAVEL OF AN UNDIVIDED OR DIVIDED FACILITY, CLOSE THE LANE ACCORDING TO THE TRAFFIC CONTROL PLANS, ROADWAY STANDARD DRAWINGS, OR AS DIRECTED BY THE ENGINEER. CONDUCT THE WORK SO THAT ALL PERSONNEL AND/OR EQUIPMENT REMAIN WITHIN THE CLOSED TRAVEL LANE.
- G) DO NOT WORK SIMULTANEOUSLY WITHIN 15 FT ON BOTH SIDES OF AN OPEN TRAVELWAY, RAMP, OR LOOP WITHIN THE SAME LOCATION UNLESS PROTECTED WITH GUARDRAIL OR BARRIER.

PAVEMENT EDGE DROP OFF REQUIREMENTS

H) BACKFILL AT A 6:1 SLOPE UP TO THE EDGE AND ELEVATION OF EXISTING PAVEMENT IN AREAS ADJACENT TO AN OPENED TRAVEL LANE THAT HAS AN EDGE OF PAVEMENT DROP-OFF AS FOLLOWS:

BACKFILL DROP-OFFS THAT EXCEED 2 INCHES ON ROADWAYS WITH POSTED SPEED LIMITS OF 45 MPH OR GREATER.

BACKFILL DROP-OFFS THAT EXCEED 3 INCHES ON ROADWAYS WITH POSTED SPEED LIMITS LESS THAN 45 MPH.

BACKFILL WITH SUITABLE COMPACTED MATERIAL, AS APPROVED BY THE ENGINEER, AT NO EXPENSE TO THE DEPARTMENT.

I) DO NOT EXCEED A DIFFERENCE OF 2 INCHES IN ELEVATION BETWEEN OPEN LANES OF TRAFFIC FOR NOMINAL LIFTS OF 1.5 INCHES. INSTALL ADVANCE WARNING "UNEVEN LANES" SIGNS (W8-11) IN ADVANCE AND A MINIMUM OF EVERY HALF MILE THROUGHOUT THE UNEVEN AREA.

TRAFFIC PATTERN ALTERATIONS

J) NOTIFY THE ENGINEER TWENTY ONE (21) CALENDAR DAYS PRIOR TO ANY TRAFFIC PATTERN ALTERATION.

SIGNING

- K) INSTALL ADVANCE WORK ZONE WARNING SIGNS WHEN WORK IS WITHIN 40 FT FROM THE EDGE OF TRAVEL LANE AND NO MORE THAN THREE (3) DAYS PRIOR TO THE BEGINNING OF CONSTRUCTION.
- L) PROVIDE SIGNING AND DEVICES REQUIRED TO CLOSE THE ROAD ACCORDING TO THE ROADWAY STANDARD DRAWINGS AND TRAFFIC CONTROL PLANS.
- M) COVER OR REMOVE ALL SIGNS AND DEVICES REQUIRED TO CLOSE THE ROAD WHEN ROAD CLOSURE IS NOT IN OPERATION.
- N) ENSURE ALL NECESSARY SIGNING IS IN PLACE PRIOR TO ALTERING ANY TRAFFIC PATTERN.

TRAFFIC CONTROL DEVICES

- O) WHEN LANE CLOSURES ARE NOT IN EFFECT SPACE CHANNELIZING DEVICES IN WORK AREAS NO GREATER IN FEET THAN TWICE THE POSTED SPEED LIMIT (MPH) EXCEPT, 10 FT ON-CENTER IN RADIUS, AND 3 FT OFF THE EDGE OF AN OPEN TRAVELWAY. REFER TO STANDARD SPECIFICATIONS FOR ROADS AND STRUCTURES SECTIONS 1130 (DRUMS), 1135 (CONES) AND 1180 (SKINNY DRUMS) FOR ADDITIONAL REQUIREMENTS.
- P) PLACE TYPE III BARRICADES, WITH "ROAD CLOSED" SIGN R11-2 ATTACHED, OF SUFFICIENT LENGTH TO CLOSE ENTIRE ROADWAY.

PROJ. REFERENCE NO.	SHEET NO.
U-5510	TMP-1B
 TGS ENGINEERS 804-C N. LAFAYETTE ST SHELBY, NC 28150 PH (704) 476-0003 CORP. LICENSE NO. C-0275	

LOCAL NOTES

UNLESS OTHERWISE NOTED MAINTAIN ACCESS TO DRIVEWAYS AT ALL TIMES USING INCIDENTAL STONE AND DRUMS TO DELINEATE THE TRAVELWAYS.

MANAGEMENT STRATEGIES

THE MAJORITY OF THE CONSTRUCTION OF THE PROPOSED SWEETWATER ROAD EXTENSION INCLUDING THE ROUND-A-BOUT AND THE -Y2- ALIGNMENT WILL BE CONSTRUCTED AWAY FROM TRAFFIC. USING FLAGGERS AND TEMPORARY ROAD CLOSURES ONLY FOR THE CONSTRUCTION OF THE TIE-INS.

THE PROPOSED CONSTRUCTION OF STARTOWN ROAD AND ROBINWOOD ROAD WILL BE PERFORMED USING TEMPORARY LANE CLOSURES AND FLAGGERS.

9/28/2017 10:55:10 AM TrafficControl\TrafficControl\TCP\U-5510_TC_TMP_01B\Proj\Ints.dgn
 User: jsmelin

**DOCUMENT NOT CONSIDERED FINAL
UNLESS ALL SIGNATURES COMPLETED**

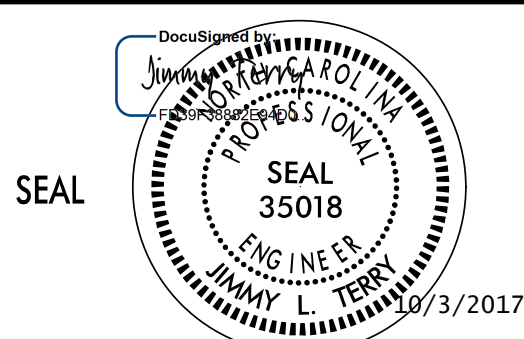
APPROVED: _____	DATE: _____
	

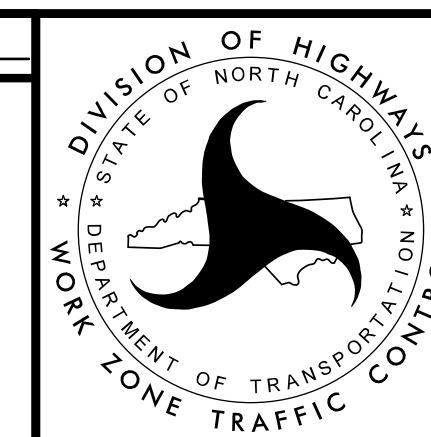

TRANSPORTATION
OPERATIONS
PLAN

PHASING

PROJ. REFERENCE NO. U-5510	SHEET NO. TMP-2
TGS ENGINEERS 804-C N. LAFAYETTE ST SHELBY, NC 28150 PH (704) 476-0003 CORP. LICENSE NO. C-0275	

PHASE I

INSTALL ALL ADVANCE WORK ZONE WARNING SIGNS ON -L- AND ALL Y-LINES IN ACCORDANCE WITH NCDOT RDY STD DRAWING 1101.01 (SHT 3 OF 3).

STEP 2:

WITHOUT DISTURBING ANY EXISTING TRAFFIC CONSTRUCT THE FOLLOWING UP TO BUT NOT INCLUDING THE FINAL LAYER OF SURFACE COURSE (SEE TMP-3):
 -L- STA 12+28 TO 33+53
 -Y2- STA 13+20 TO 15+15

CONSTRUCT THE ADJACENT SIDEWALK, RETAINING WALL, AND CURB AND GUTTER.

CONSTRUCT THE DRIVEWAY RT OF -L- STA. 32+80.00

ON THE WESTSIDE OF SWEETWATER RD EXT (-L-) TIE THE CURB AND GUTTER TO EXISTING AT -L- STA 33+58.36 AND PLACE THE SIDEWALK TO -L- STA 33+77.53 AS SHOWN ON PLANS (SEE TMP-3).

UNTIL FUTURE CONSTRUCTION CLOSE Y2- AT STA 13+20 AND 15+15 USING GUARDRAIL AS SHOWN ON PLANS (SEE TMP-3).

INSTALL THE ROADWAY DRAINAGE ALONG -L- (SWEETWATER RD EXT.) AND -Y2-, INCLUDING THE CULVERT ON THE TRIB. TO CLARK CREEK AT -L- STA 24+78+/- (SEE ROADWAY PLANS)

PHASE II

WORK IN THIS PHASE TAKES PLACE IN 2 DIFFERENT AREAS:

- AREA A - WORK ALONG STARTOWN RD (-Y1-) AND ROBINWOOD RD (-L-)
- AREA B - SWEETWATER RD EXT (-L-) WIDENING AND TIE-IN TO 21' ST DR SE

THE CONTRACTOR CAN WORK CONCURRENTLY IN BOTH AREAS.

AREA A

WITH TRAFFIC IN ITS EXISTING PATTERN DO THE FOLLOWING:

STEP 1:

USING TEMPORARY LANE CLOSURES AND FLAGGERS AS NEEDED CONSTRUCT THE NORTHSIDE WIDENING AND SHOULDER UP TO BUT NOT INCLUDING THE FINAL LAYER OF SURFACE COURSE ALONG -Y1- (STARTOWN RD) FROM -Y1- STA. 11+07 TO 26+00. (SEE TMP 4 & 5).

CONSTRUCT THE WIDENING AND SHOULDERS OF ROBINWOOD DR (-L-) UP TO BUT NOT INCLUDING THE FINAL LAYER OF SURFACE COURSE FROM -L- STA 8+00 TO 11+92. (SEE TMP-4 & 5).

BEGIN THE INSTALLATION OF THE ROADSIDE DRAINAGE ALONG -Y1- (STARTOWN RD) AND -L- (ROBINWOOD DR) (SEE ROADWAY PLANS).

MAINTAIN ACCESS TO ALL DRIVEWAYS AT ALL TIMES.

SEE RDY STD DWG 1101.02 (SHT 1 OF 15) AND RDY STD DWG 1101.04

STEP 2:

USING TEMPORARY LANE CLOSURES AND FLAGGERS CONSTRUCT ROBINWOOD DR (-L-) UP TO BUT NOT INCLUDING THE FINAL LAYER OF SURFACE COURSE FROM -L- STA 8+00 TO 11+92. (SEE TMP-4 & 5)

COMPLETE THE INSTALLATION OF THE ROADWAY DRAINAGE ALONG -Y1- (STARTOWN RD) AND -L- (ROBINWOOD DR) (SEE ROADWAY PLANS).

MAINTAIN ACCESS TO ALL DRIVEWAYS AT ALL TIMES.

SEE RDY STD DWG 1101.02 (SHT 1 OF 15)

STEP 3:

USING TEMPORARY LANE CLOSURES AND FLAGGERS PLACE THE TEMPORARY PAVEMENT MARKINGS AS FOLLOWS (SEE TMP-6):
 -L- STA. 8+00 TO 11+92 & -Y1- STA. 11+07 TO 26+00

USING TEMPORARY LANE CLOSURES AND FLAGGERS PLACE THE FINAL LAYER OF SURFACE COURSE AS FOLLOWS (SEE TMP-6):
 -L- STA. 8+00 TO 11+92 & -Y1- STA. 11+07 TO 26+00

USING TEMPORARY LANE CLOSURES AND FLAGGERS PLACE FINAL PAVEMENT MARKINGS AND MARKERS AS FOLLOWS (SEE TMP-6 & PAVEMENT MARKING PLANS)
 -L- STA. 8+00 TO 11+92 & -Y1- STA. 11+07 TO 26+00

PRIOR TO OPENING SWEETWATER ROAD EXT. (-L-) TO TRAFFIC AND OPEN THE NEW TRAFFIC PATTERN ON STARTOWN RD (-Y1-) USE DRUMS TO DELINEATE TRAFFIC TO REMAIN IN ITS EXISTING PATTERN.

MAINTAIN ACCESS TO ALL DRIVEWAYS AT ALL TIMES.

SEE RDY STD DWG 1101.02 (SHT 1 OF 15)

AREA B

WITH TRAFFIC IN ITS EXISTING PATTERN DO THE FOLLOWING

STEP 1:

USING TEMPORARY LANE CLOSURES AND FLAGGERS CONSTRUCT THE EASTSIDE 21' ST DR (-L-) WIDENING FROM -L- STA 33+53 TO 37+65.92 UP TO BUT NOT INCLUDING THE FINAL LAYER OF SURFACE COURSE. (SEE TMP-4 & 7).

MAINTAIN ACCESS TO ALL DRIVEWAYS AT ALL TIMES.

SEE RDY STD DWG 1101.02 (SHT 1 OF 15) AND RDY STD DWG 1101.04

STEP 2:

AFTER PLACING ALL INCOMING AND OUTGOING TRAFFIC ONTO THE DRIVEWAY AT -L- STA 35+30 LT CLOSE 21' ST DR SE (-L-) AT -L- STA 34+50 TO TRAFFIC. MILL AND WEDGE THE EXISTING PAVEMENT FROM -L- STA 33+53 TO 34+50 AS NECESSARY TO ALLOW THE PLACEMENT OF THE FINAL LAYER OF SURFACE COURSE IN THE NEXT STEP. (SEE TMP-4 & 7).

STEP 3:

USING TEMPORARY LANE CLOSURES AND FLAGGERS WHERE NECESSARY PLACE THE FINAL LAYER OF SURFACE COURSE AND THE FINAL PAVEMENT MARKINGS AS FOLLOWS (SEE TMP 4 & 8, SEE PAVEMENT MARKING PLANS):
 -L- STA. 12+32 TO 37+65.92
 -Y2- STA. 13+20 TO 15+15

PHASE III

REMOVE ALL BARRIERS, DRUMS AND OTHER TRAFFIC CONTROL DEVICES FROM SWEETWATER RD EXT. (-L-), ROBINWOOD DR (-L-), STARTOWN RD (-Y1-) AND -Y2- CONSTRUCTION AND OPEN ALL TO TRAFFIC.

DOCUMENT NOT CONSIDERED FINAL
UNLESS ALL SIGNATURES COMPLETED

APPROVED: _____	DATE: _____

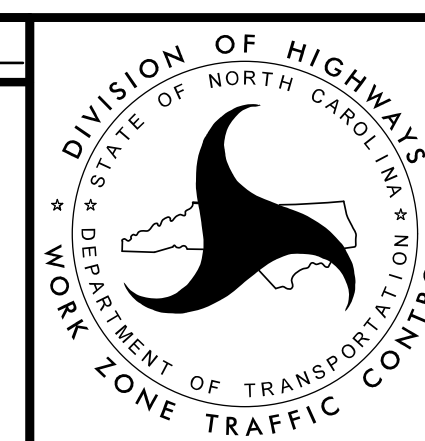

PHASING

9/28/2017 9:11:00 AM U:\5510\TrafficControl\TCP\U-5510_TC_TMP_02(Phasing).dgn User: jsmelvin

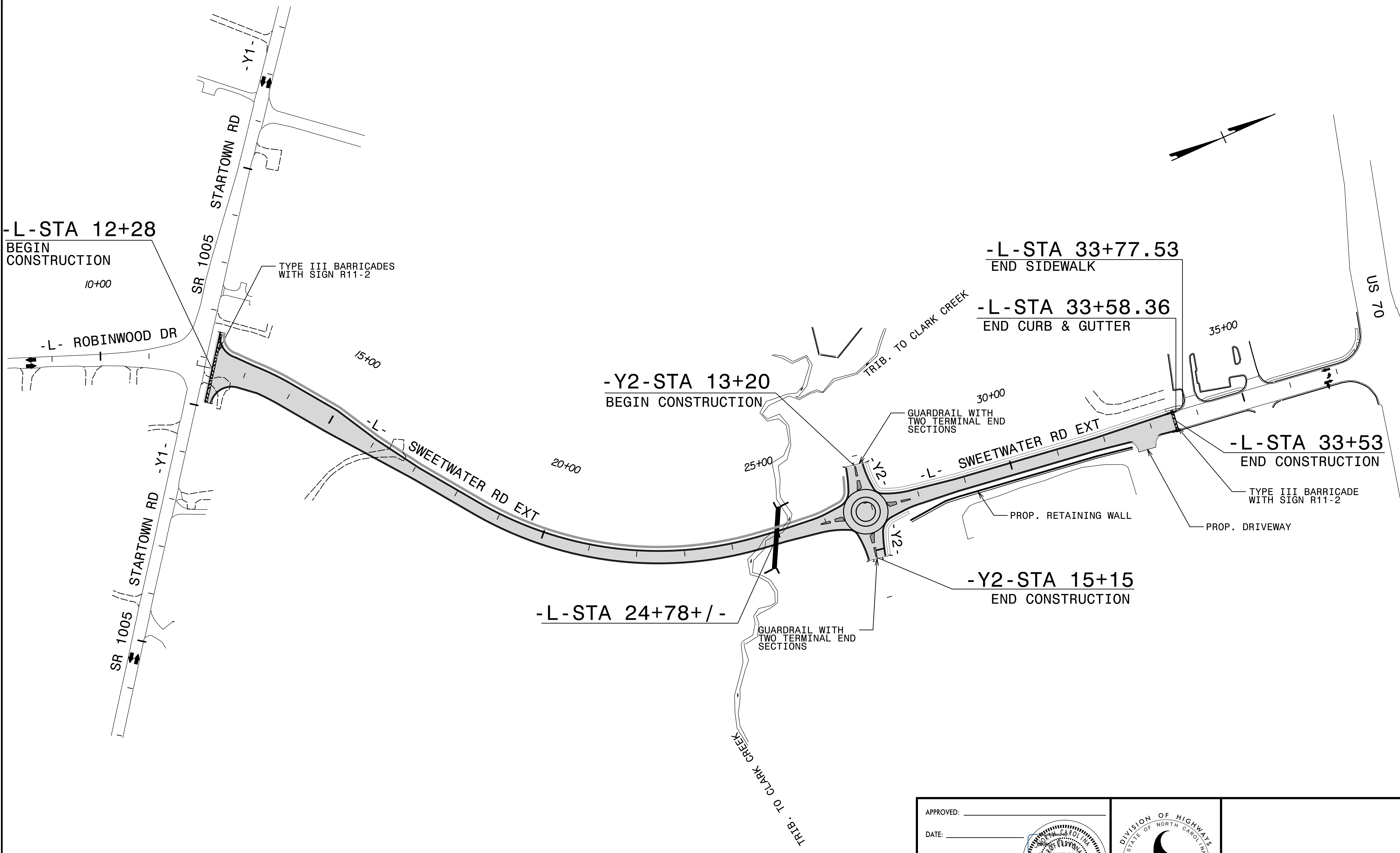

9/28/2017 10:55:00 AM TrafficControl\TCP\U-5510_TC_TMP_03_00\01.dgn User:jsmevin

APPROVED: _____
 DATE: _____

SEAL

10/3/2017

**DOCUMENT NOT CONSIDERED FINAL
 UNLESS ALL SIGNATURES COMPLETED**

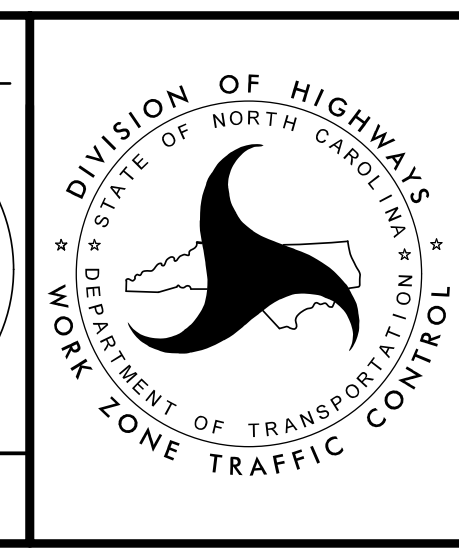

PHASE I OVERVIEW

AREA A:

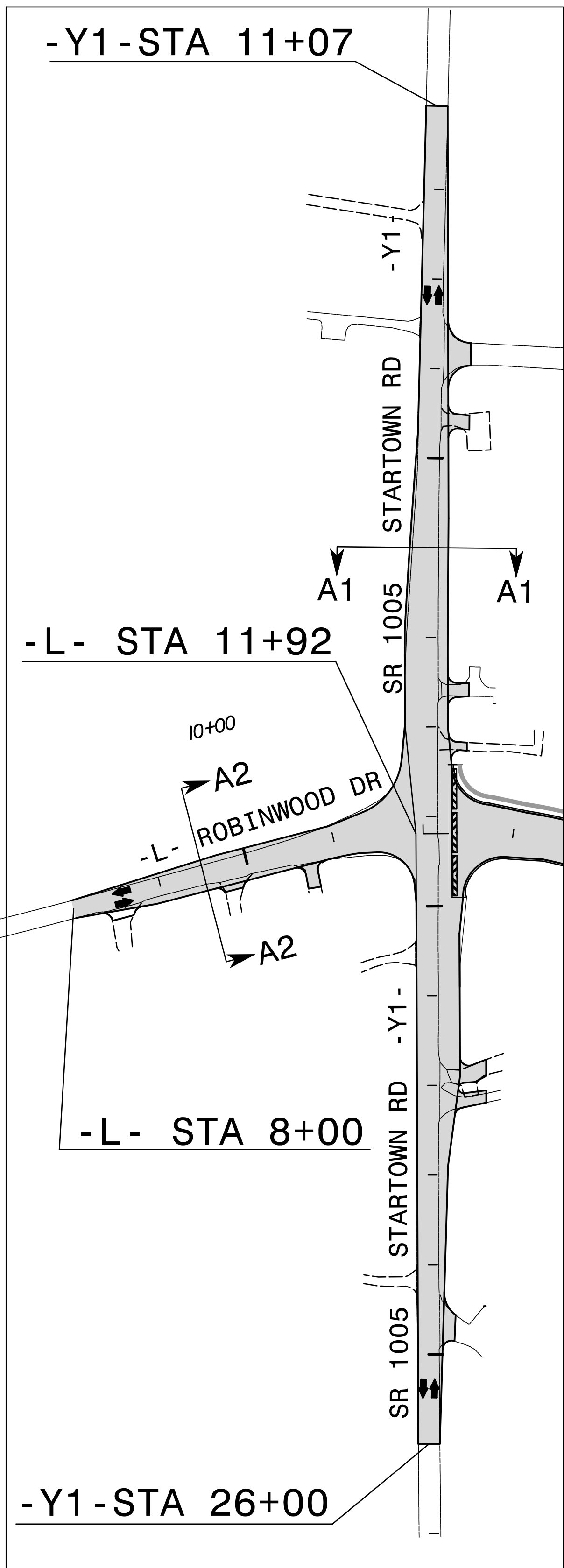

AREA B:

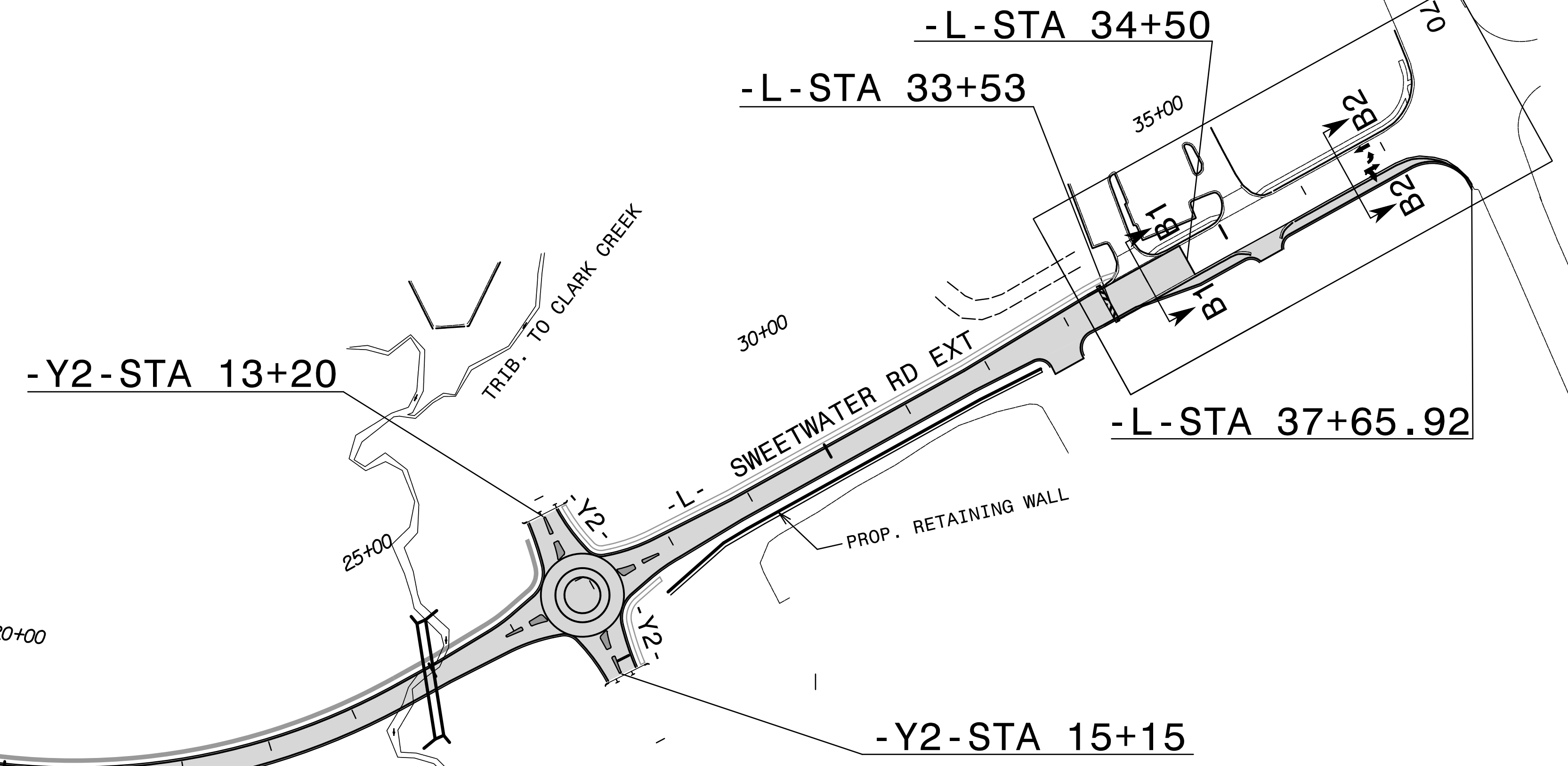

9/28/2017 10:55:10 AM User: jsmelvin \\TCPU-U-5510\Traffic\TrafficControl\TCP-U-5510_TC_TMP_04_(0V02).dgn

APPROVED: _____
 DATE: _____

SEAL
 10/3/2017

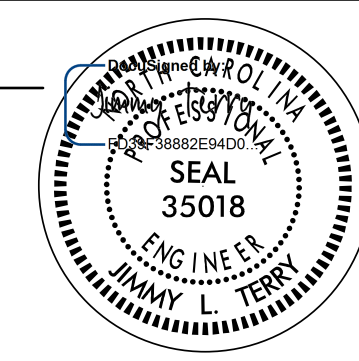
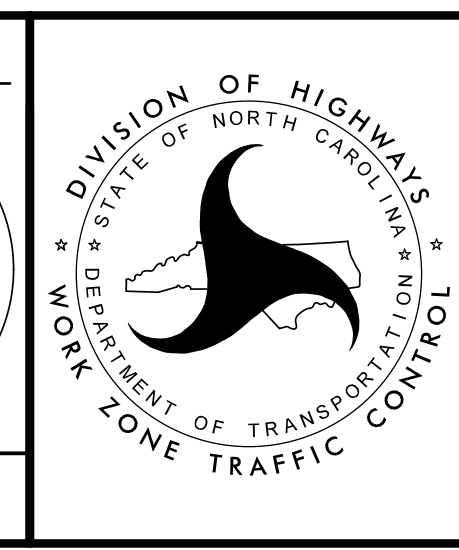
PHASE II OVERVIEW

DOCUMENT NOT CONSIDERED FINAL
UNLESS ALL SIGNATURES COMPLETED

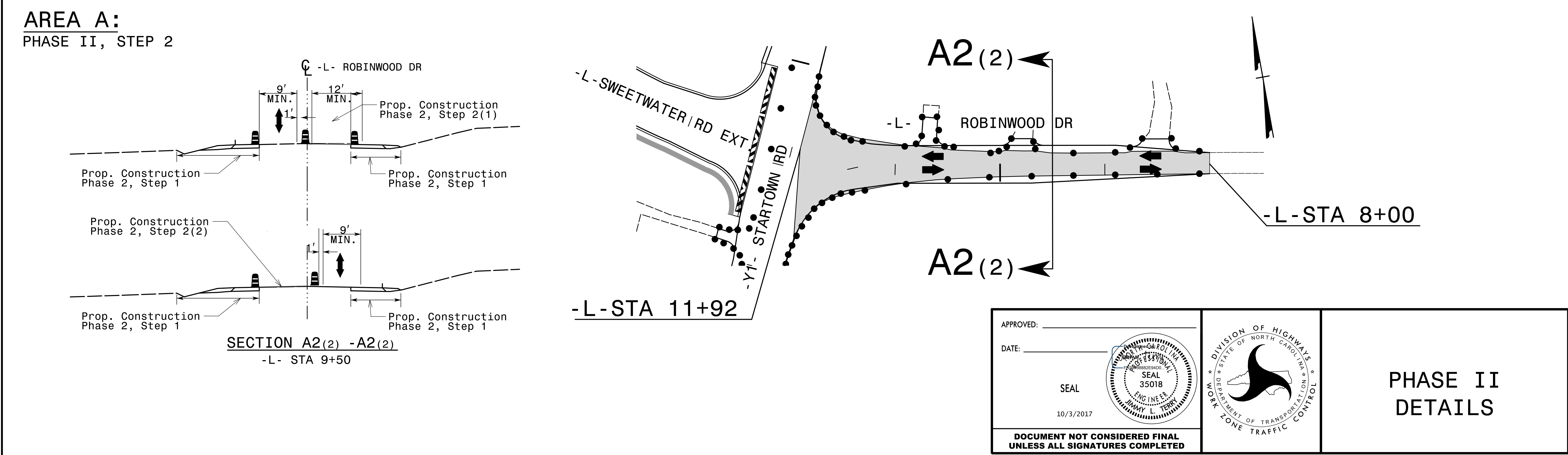
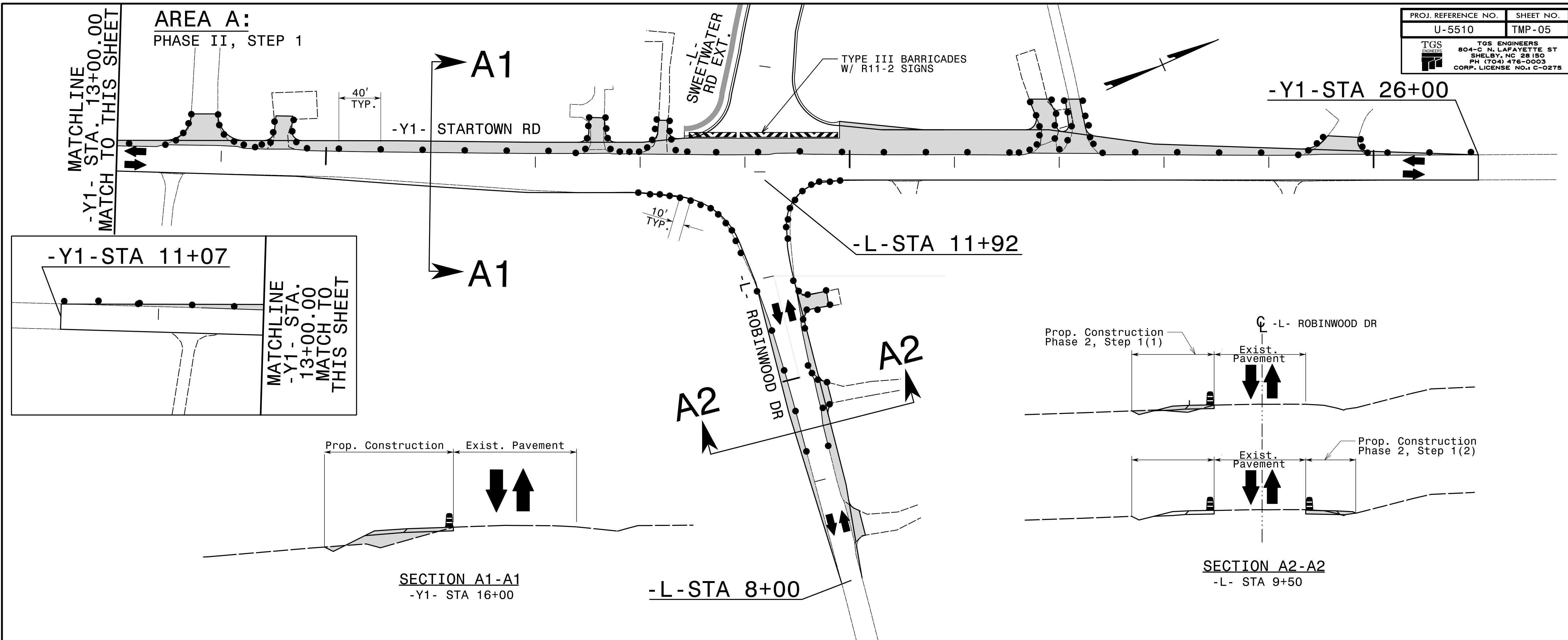

9/28/2017
 X:\TC\U-5510\TrafficControl\TCP\U-5510_TC_TMP_05_01\DETAILS_PH02.dgn
 User: jsmelvin

AREA A:
PHASE II, STEP 3

PROJ. REFERENCE NO.	SHEET NO.
U-5510	TMP-6
 TGS ENGINEERS 804-C N. LAFAYETTE ST SHELBY, NC 28150 PH (704) 476-0003 CORP. LICENSE NO. 1 C-0275	

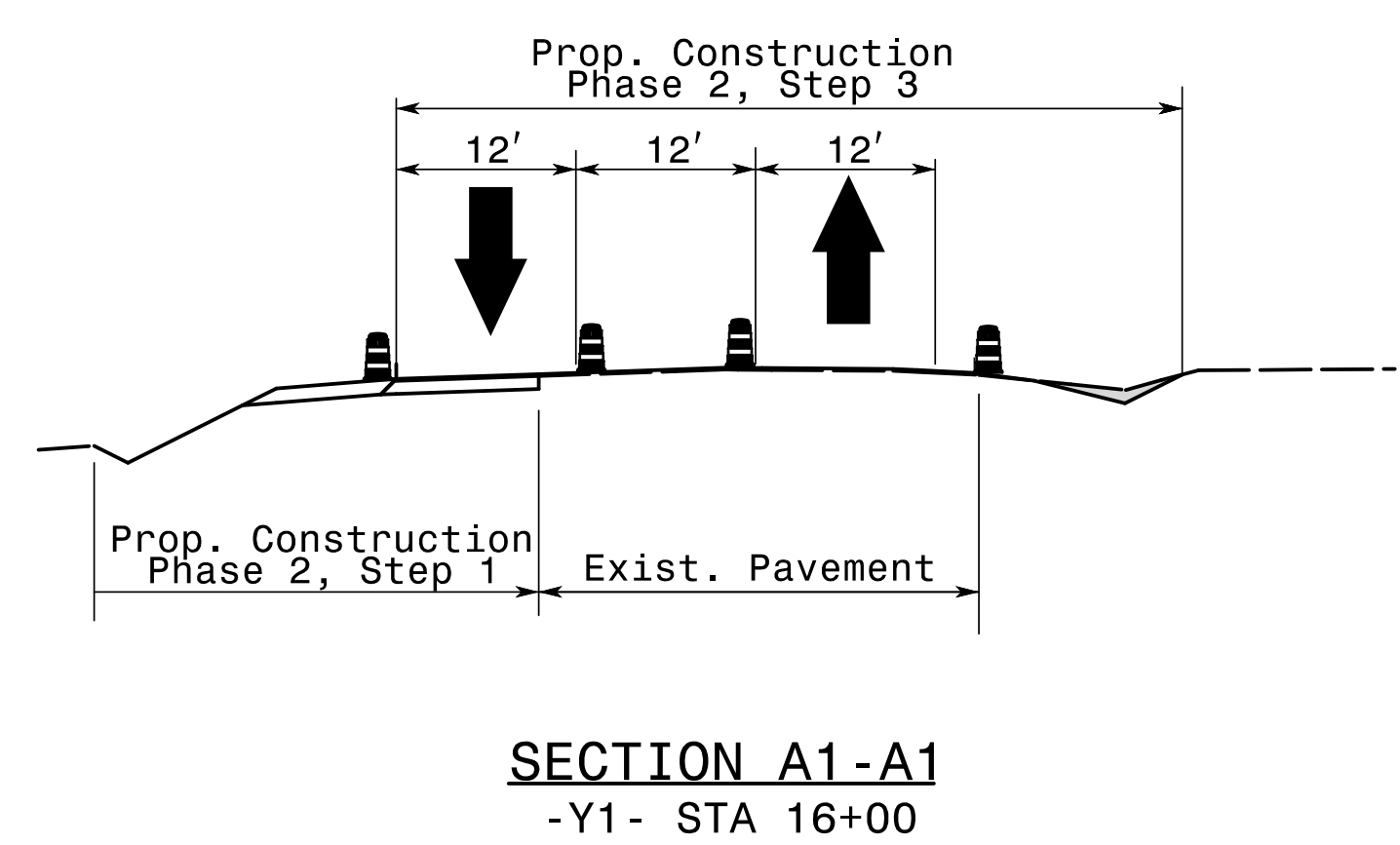
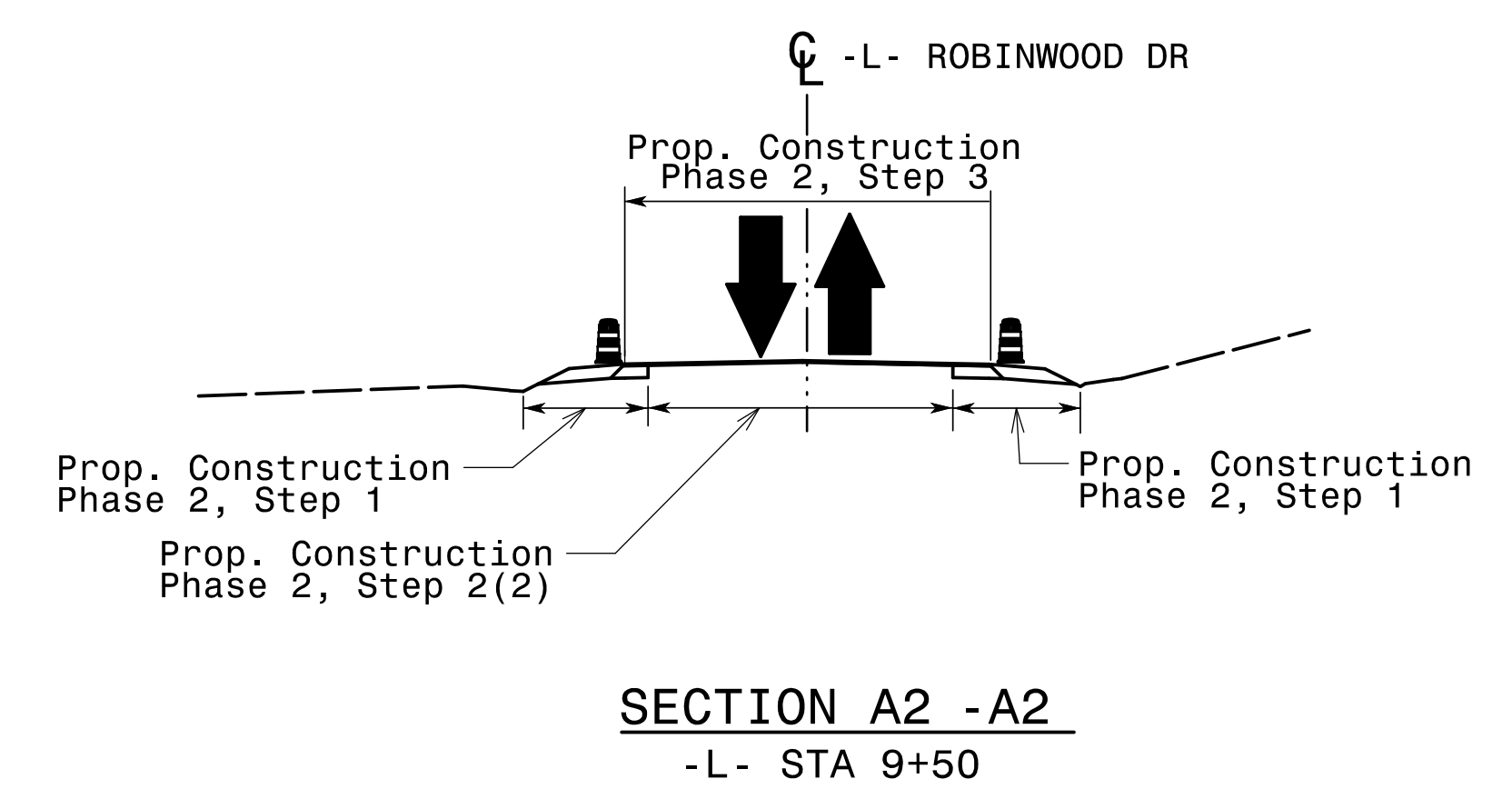
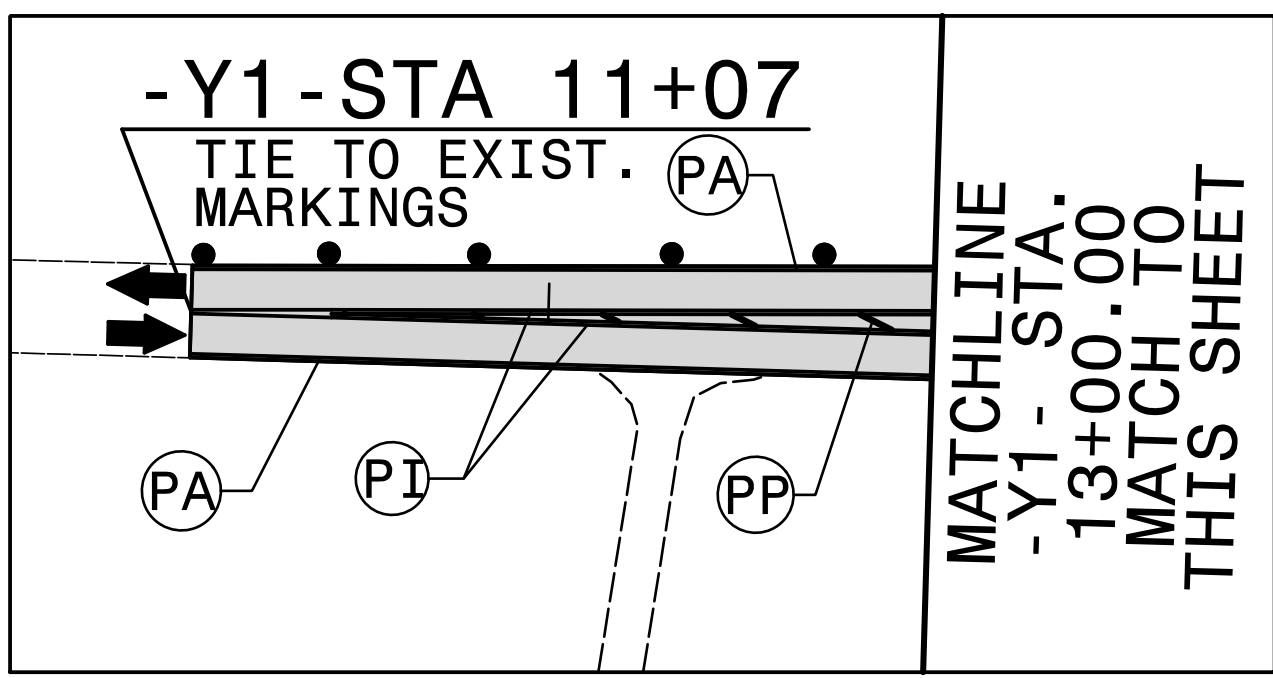
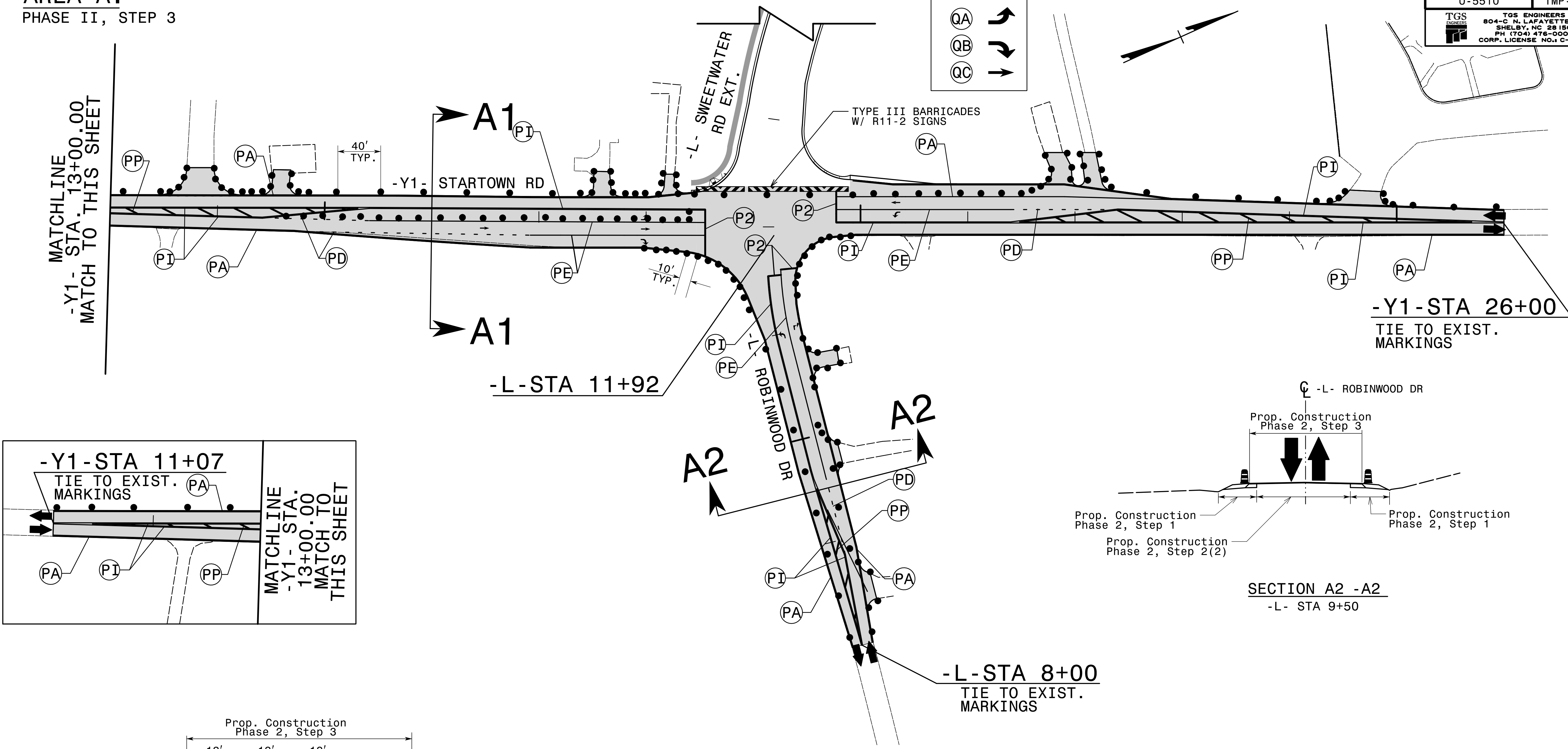

TEMPORARY PAVEMENT MARKINGS SCHEDULE	
SYMBOL	DESCRIPTION
PAINT (24")	
P2	WHITE STOPBAR
PAINT (4")	
PA	WHITE EDGELINE
PD	3 FT. - 9 FT./SP WHITE MINISKIP
PE	WHITE SOLID LANE LINE
PI	YELLOW DOUBLE CENTER
PAINT (6")	
PP	YELLOW DIAGONAL
PAINT MARKING SYMBOLS	
QA	LEFT TURN ARROW
QB	RIGHT TURN ARROW
QC	STRAIGHT ARROW

NOTE: SEE PAVEMENT MARKING PLANS FOR FINAL PAVEMENT MARKING LAYOUT AND SCHEDULE

APPROVED: _____
DATE: _____

SEAL
10/3/2017

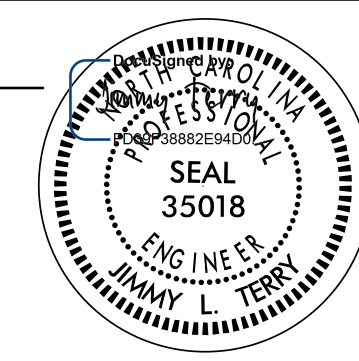
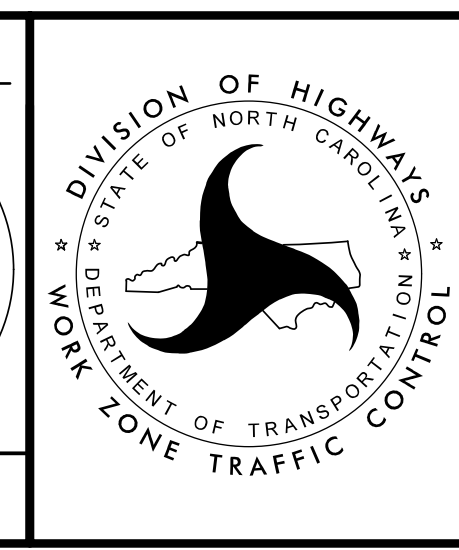
**PHASE II
DETAILS**

10/2/2017 10:15:00 AM U:\Traffic\TrafficControl\TCP\U-5510_TC_TMP_06_06_06\DETAILS_PH02.dgn User:tsmevin

AREA B:
PHASE II, STEP 1

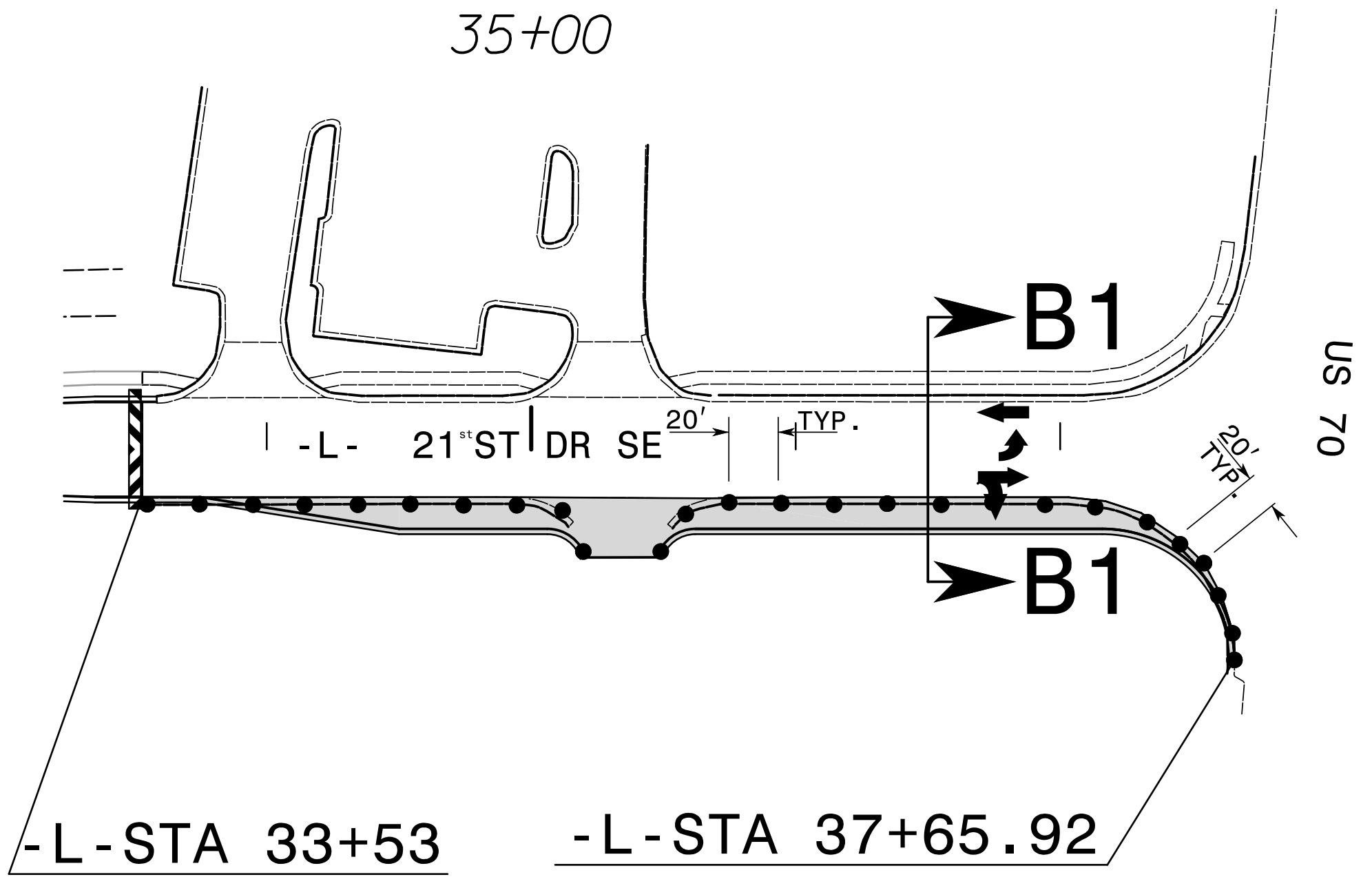

AREA B:
PHASE II, STEP 2

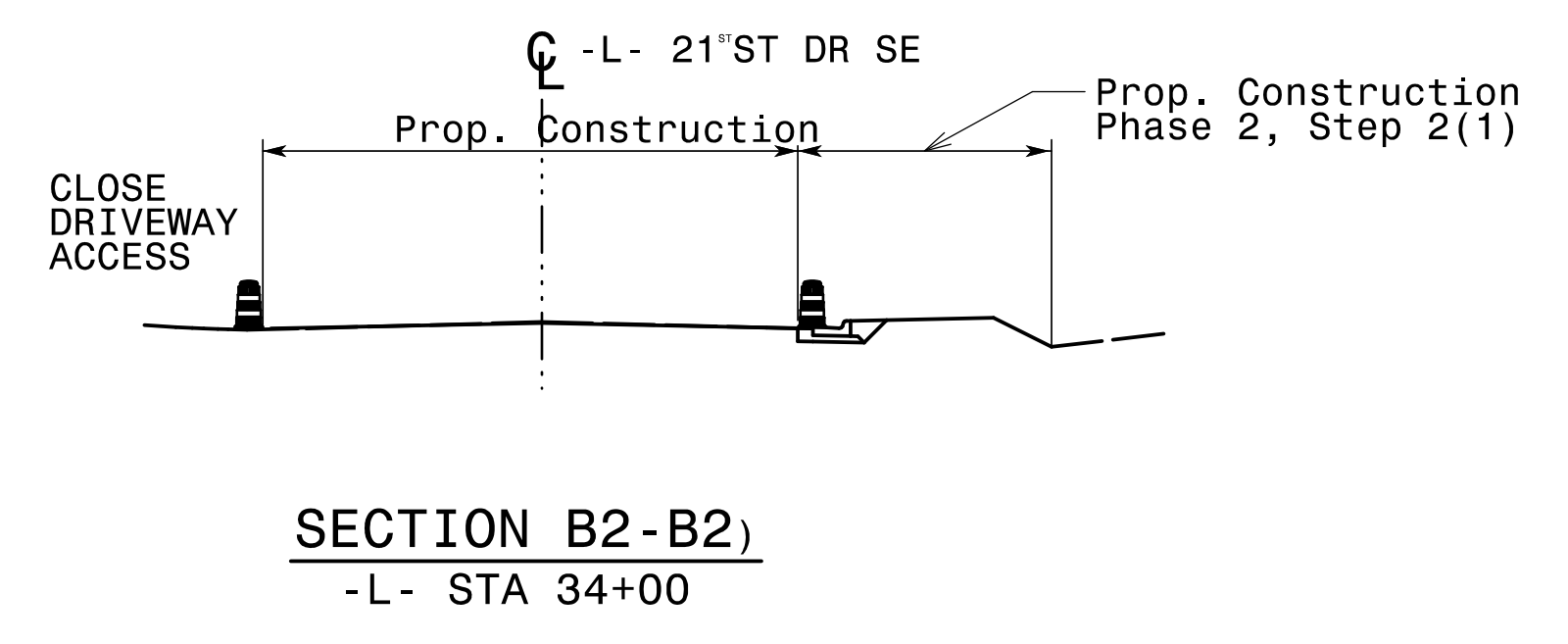
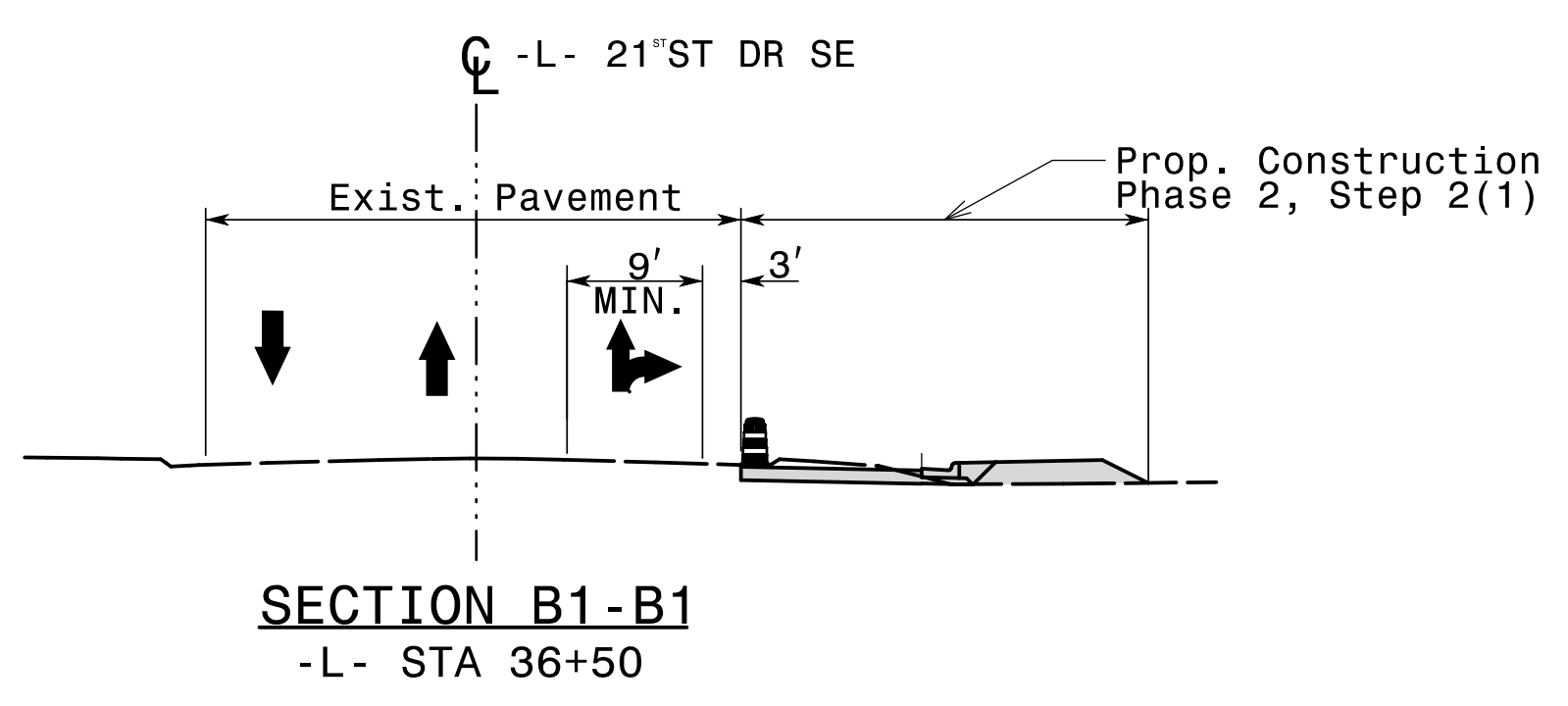
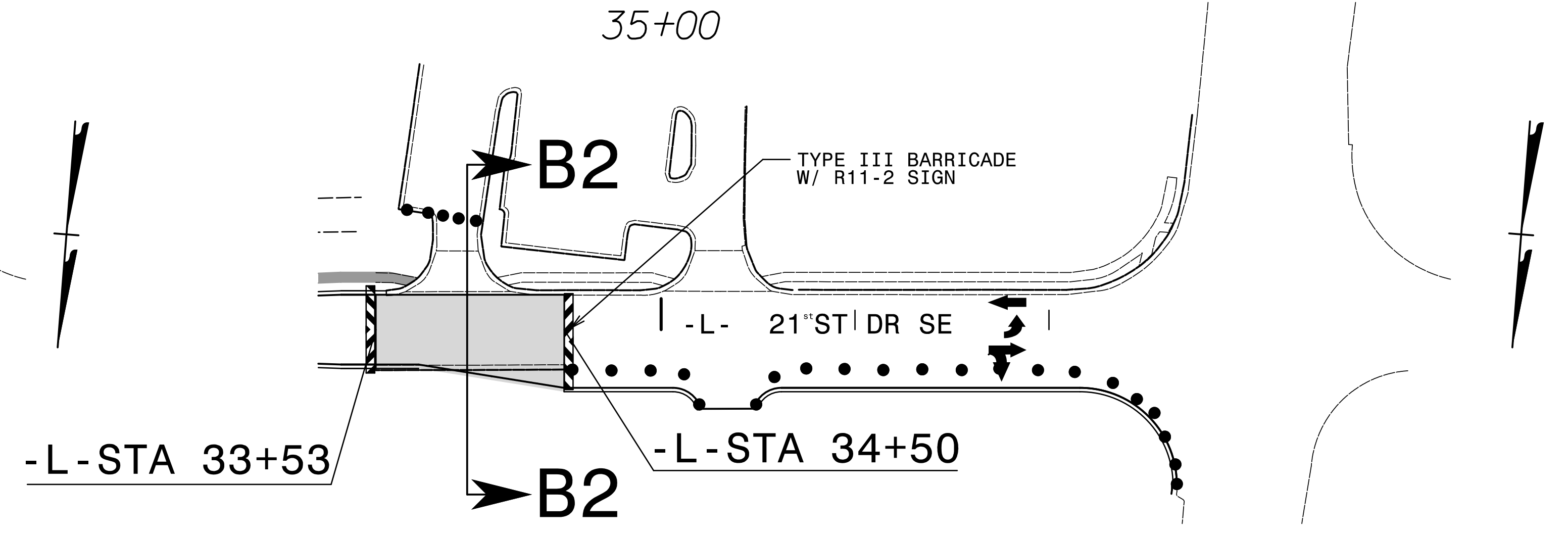

9/28/2017
 \\TC\U-5510\Traffic\TrafficControl\TCP\U-5510_TC_TMP_07_DETAILS_PH021.dgn
 User: jsmelvin

APPROVED: _____
 DATE: _____

SEAL

10/3/2017

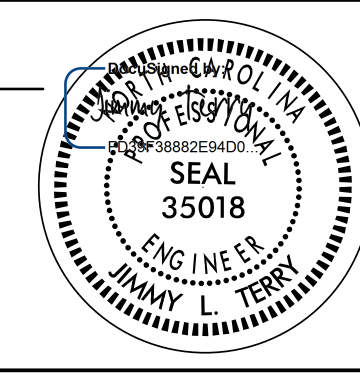
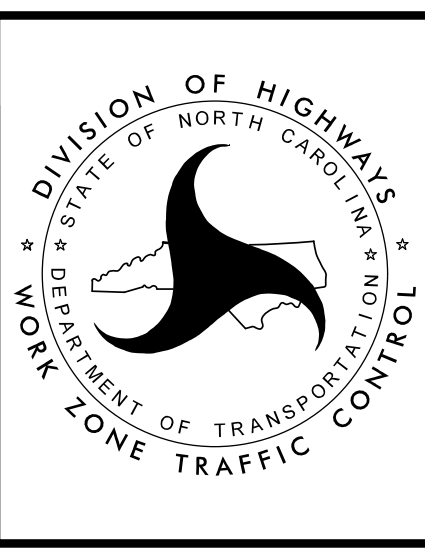
**PHASE II
DETAILS**

**DOCUMENT NOT CONSIDERED FINAL
UNLESS ALL SIGNATURES COMPLETED**

AREA B:
PHASE II, STEP 3

PROJ. REFERENCE NO.	SHEET NO.
U-5510	TMP-8
 TGS ENGINEERS 804-C N. LAFAYETTE ST SHELBY, NC 28150 PH (704) 476-0003 CORP. LICENSE NO. 1 C-0275	

NOTE: SEE PAVEMENT MARKING PLANS
FOR PAVEMENT MARKING LAYOUT AND SCHEDULE

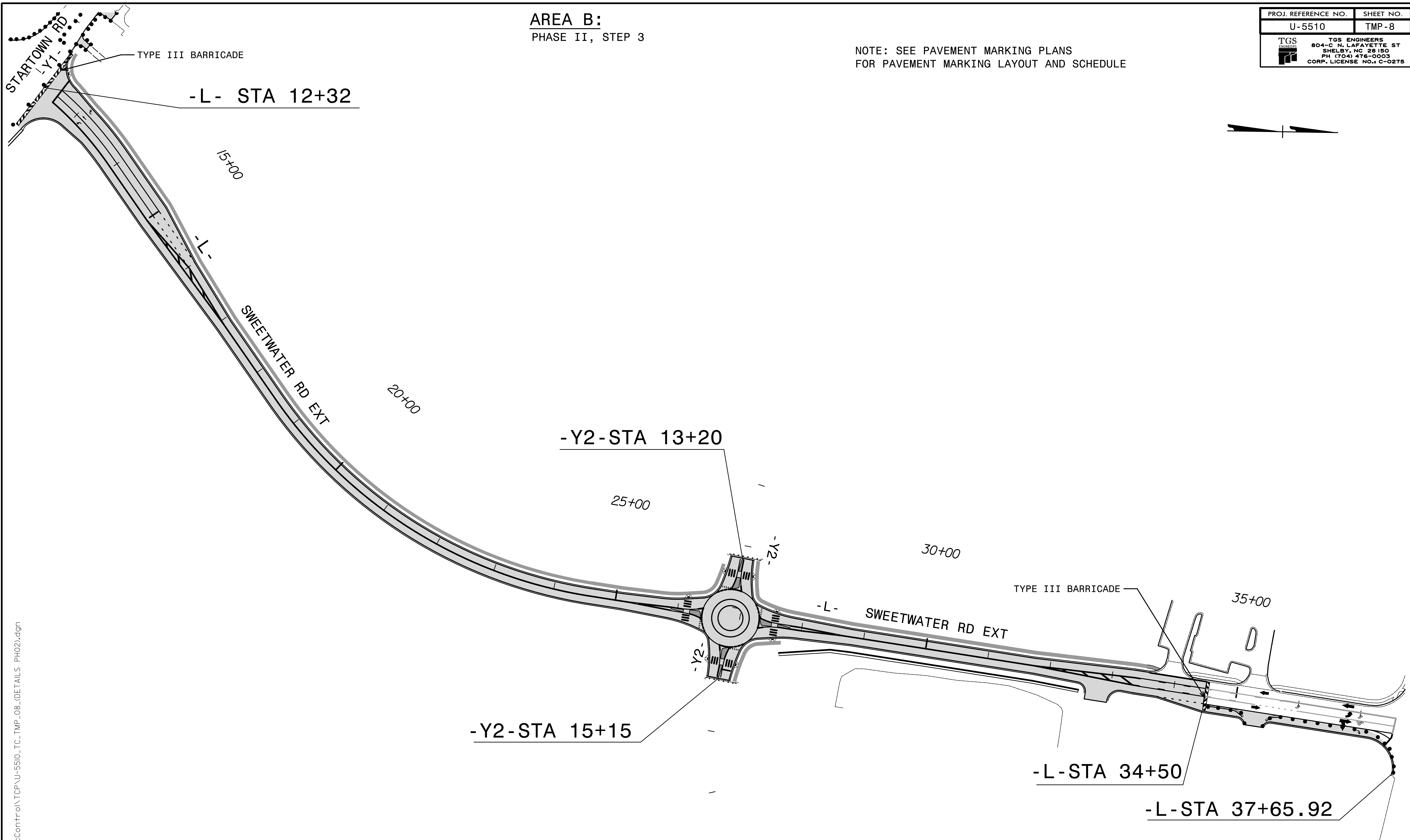
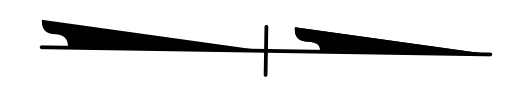

9/29/2017
X:\NCDOT\U-5510\TrafficControl\TCP\U-5510_TC_TMP_08_IDETAILS_PH021.dgn
User:smelvin

DOCUMENT NOT CONSIDERED FINAL
UNLESS ALL SIGNATURES COMPLETED

APPROVED: _____ DATE: _____

SEAL

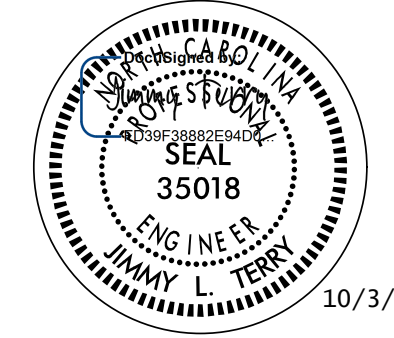

10/3/2017

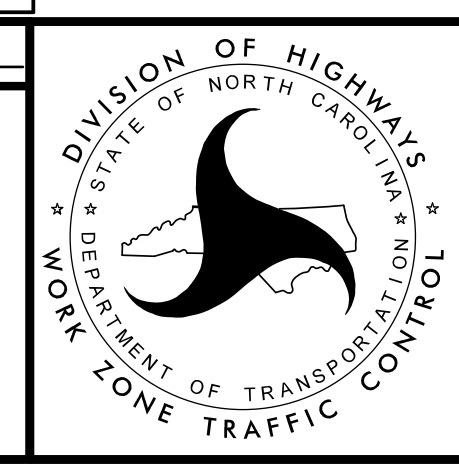

**PHASE II
DETAILS**